

LA LIAISON COMPLETE

Définition, liaisons complètes démontables (adhérence ou obstacle), permanentes, solutions constructives.

1. Introduction

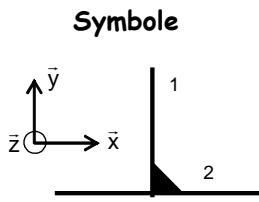

Degrés de liberté

	T	R
\bar{x}
\bar{y}
\bar{z}

Pourquoi ?

-
-

Comment ?

.....
.....



Diagramme F.A.S.T. d'une liaison complète



Remarque :

2. Liaisons complètes démontables

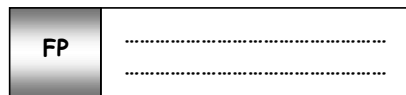
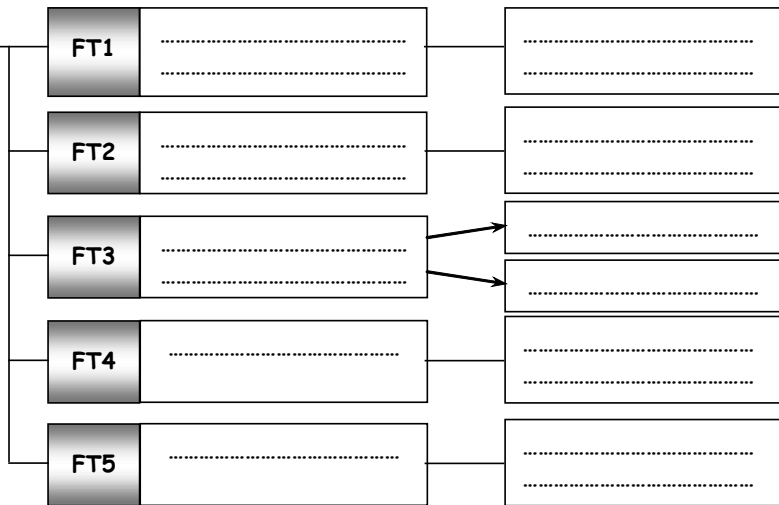
2.1. Liaisons complètes par adhérence

Exemples	Surfaces assurant la MIP	Éléments assurant le MAP	Remarques

<p style="text-align: center;">Pincement</p>
<p style="text-align: center;">Emmancement conique</p>

2.2. Par obstacle

Lorsque l'adhérence ne suffit plus pour transmettre l'effort, le plus souvent, on ajoute au dispositif réalisant les fonctions techniques 1 et 2, un élément

2.2.1. Les goupilles

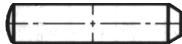
- Goupille cylindrique 

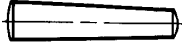
- Goupille conique 

- Goupille cannelée 

- Goupille élastique 

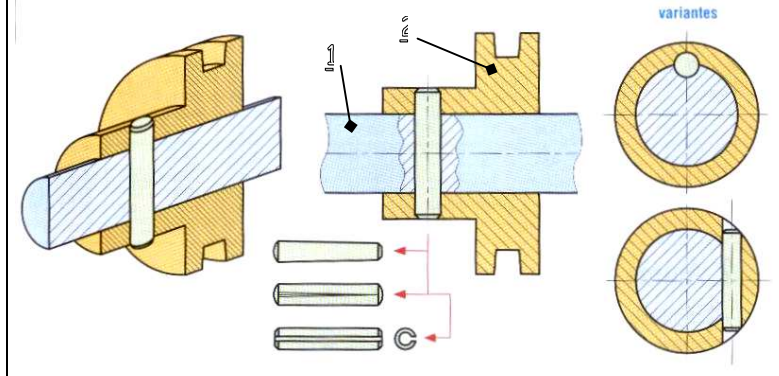
Exemple	MIP	MAP	Remarque
	<p>.....</p> <p>.....</p> <p>.....</p> <p>.....</p>	<p>.....</p> <p>.....</p> <p>.....</p> <p>.....</p>	<p>.....</p> <p>.....</p> <p>.....</p> <p>.....</p>

2.2.2. Les clavettes

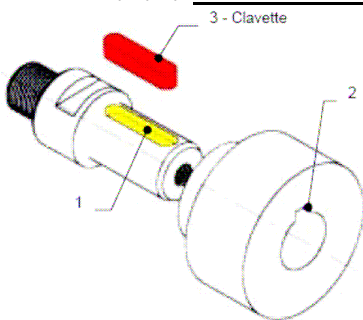

- Clavette parallèle (voir tableau)

- Clavette disque

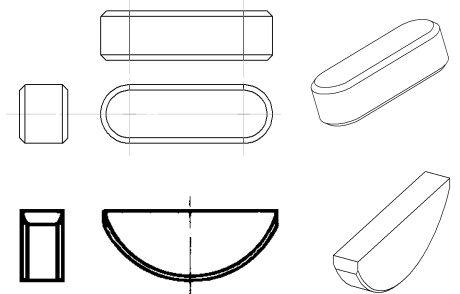

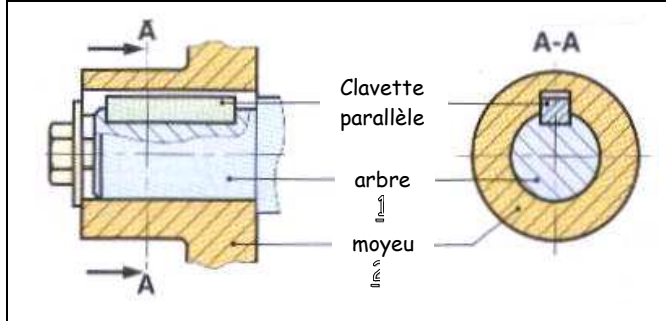
Exemple	MIP	MAP	Remarque
	<p>.....</p> <p>.....</p> <p>.....</p> <p>.....</p>	<p>.....</p> <p>.....</p> <p>.....</p> <p>.....</p>	<p>.....</p> <p>.....</p> <p>.....</p> <p>.....</p>

2.2.3. Les cannelures

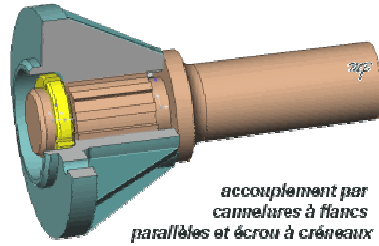
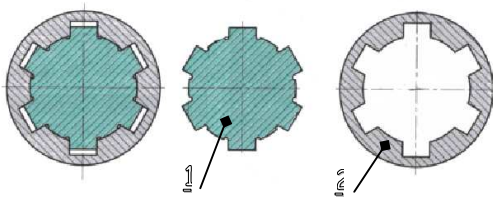

2.2.4. Les formes spéciales

Exemple	MIP	MAP	Remarque

3. Liaisons complètes permanentes

3.1. Assemblage par ajustement serré

Exemples d'ajustements serrés		observations	
H7u6 H7s6	assemblage fortement serré pouvant transmettre des efforts importants	presse lourde ou frettage	avec détérioration des pièces au démontage
H7r6 H7p6	assemblage assez serré assemblage serré pouvant transmettre des efforts sans organes d'arrêt	presse	
H7n6 H7m6	assemblage sous faible pression organe d'arrêt (clavette...) nécessaire en rotation organe d'arrêt pas forcément nécessaire en translation	assemblage parfois possible au maillet	sans détérioration des pièces au démontage
	assemblage légèrement serré organes d'arrêt nécessaires en rotation et translation		

3.1.1. Emmanchement forcé

Exemple		
<p>avant montage</p> <p>arbre</p> <p>moyeu</p>	<p>après montage</p> <p>serriage</p>	
MIP	MAP	Remarque

3.1.2. Frettage

Il existe 3 possibilités:

-
-
-

Exemples

MIP	MAP	Remarque
.....
.....

3.2. Rivetage

3.2.1. Rivet massif

Il peut avoir une tête,,

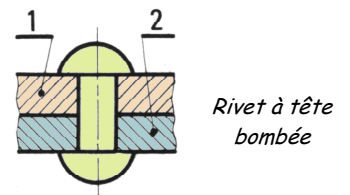

3.2.2. Rivet creux

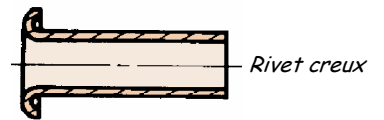

3.2.3. Rivet « pop »

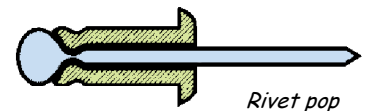

3.3. Soudage

Définition :
 De tous les procédés de base d'assemblage, le soudage est l'un des plus important, il existe de nombreuses méthodes pour souder deux pièces.

Remarque :

3.3.1. Soudage à l'arc électrique

.....

3.3.2. Soudage électrique par résistance

.....

3.3.3. Soudage au gaz, soudage par pression (vibrations, ultrasons, friction...)

3.4. Collage

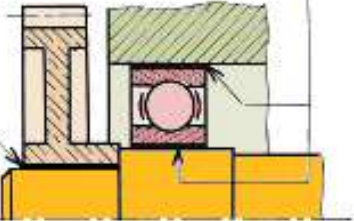
Exemple	MIP	MAP	Remarque
<p>Collé par bloc presse 601 Collé par scabroulement 641</p> 	<p>..... </p>	<p>..... </p>	<p>..... </p>

3.5. Sertissage et Agrafage

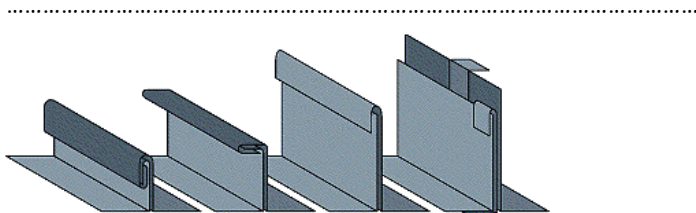

4. Applications

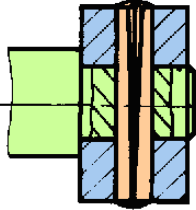
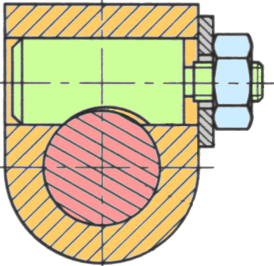
Solutions technologiques	Qualification	MIP	MAP
	<p>..... </p>	<p>..... </p>	<p>..... </p>
	<p>..... </p>	<p>..... </p>	<p>..... </p>

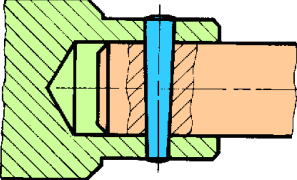
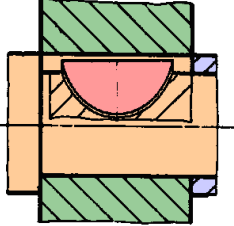
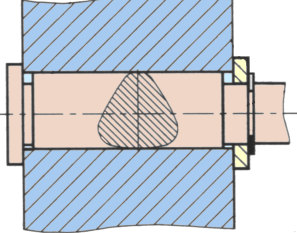
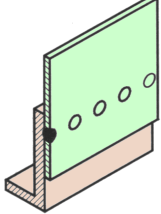
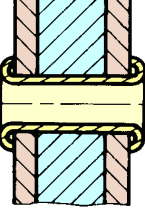
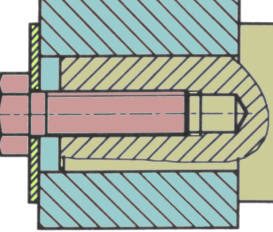
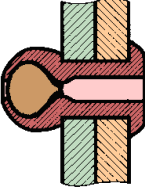
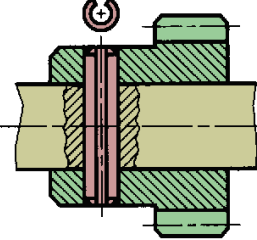
	<p>.....</p> <p>.....</p> <p>.....</p>	<p>.....</p> <p>.....</p> <p>.....</p>	<p>.....</p> <p>.....</p> <p>.....</p>
	<p>.....</p> <p>.....</p> <p>.....</p>	<p>.....</p> <p>.....</p> <p>.....</p>	<p>.....</p> <p>.....</p> <p>.....</p>
	<p>.....</p> <p>.....</p> <p>.....</p>	<p>.....</p> <p>.....</p> <p>.....</p>	<p>.....</p> <p>.....</p> <p>.....</p>
	<p>.....</p> <p>.....</p> <p>.....</p>	<p>.....</p> <p>.....</p> <p>.....</p>	<p>.....</p> <p>.....</p> <p>.....</p>
	<p>.....</p> <p>.....</p> <p>.....</p>	<p>.....</p> <p>.....</p> <p>.....</p>	<p>.....</p> <p>.....</p> <p>.....</p>
	<p>.....</p> <p>.....</p> <p>.....</p>	<p>.....</p> <p>.....</p> <p>.....</p>	<p>.....</p> <p>.....</p> <p>.....</p>
	<p>.....</p> <p>.....</p> <p>.....</p>	<p>.....</p> <p>.....</p> <p>.....</p>	<p>.....</p> <p>.....</p> <p>.....</p>
	<p>.....</p> <p>.....</p> <p>.....</p>	<p>.....</p> <p>.....</p> <p>.....</p>	<p>.....</p> <p>.....</p> <p>.....</p>